

Control Valves Positioner

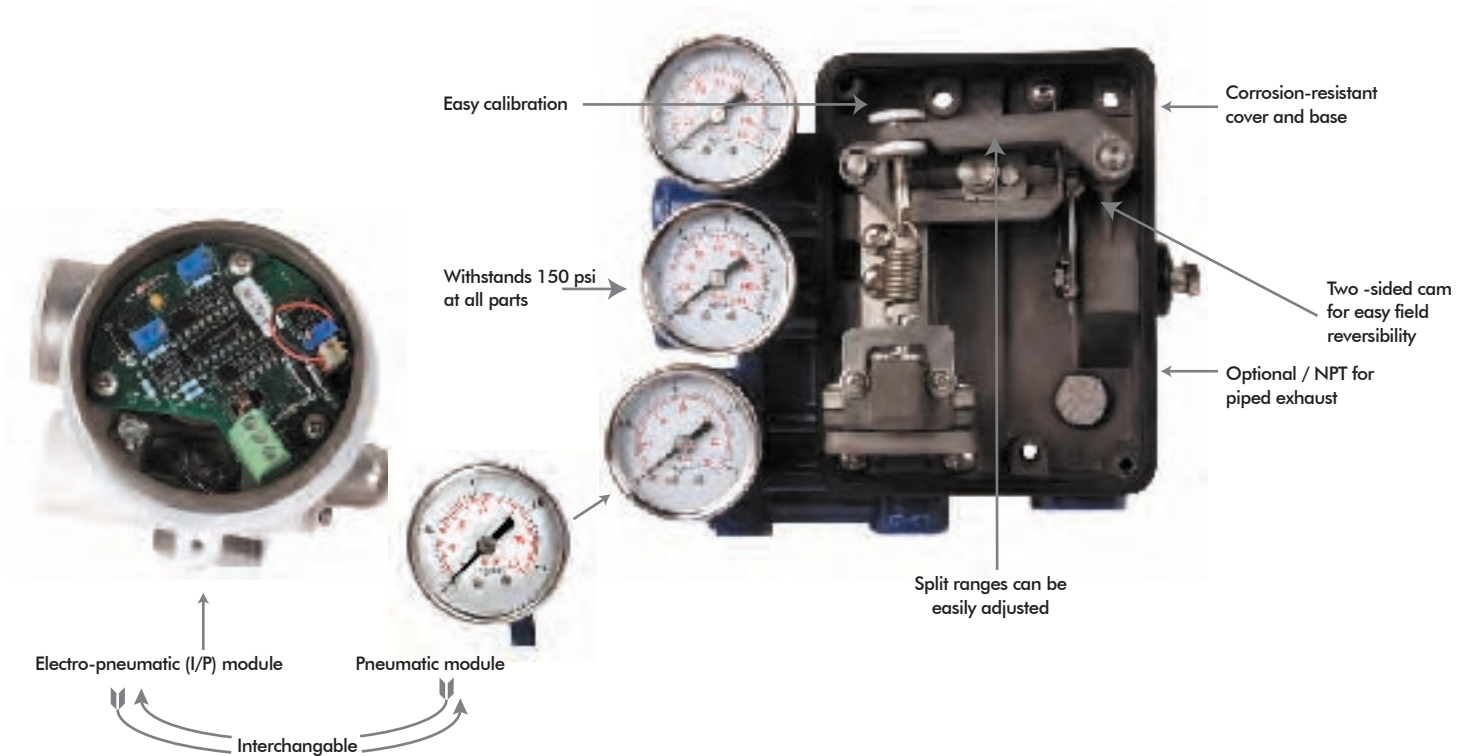

HiFlo

Valve Features



Valve positioners are primarily utilized by Mascot. A pneumatic module for air control signals, or an electro-pneumatic (I/P) module for milliamp electrical control signals is offered with Mascot valve positioner. Valve positioners are single or double-acting, force-balanced instruments that provide fast, sensitive and accurate positioning of cylinder and diaphragm actuators. These positioners being compact, field reversible, are designed for high performance and are reliable because of the rugged built.

Features

- **P/P or I/P Signal Convertible** – Easy accomplishment of field conversion from one control signal to another by replacing one module with another
- **Corrosion Resistant** – Epoxy powder painted on cover and base assembly and continuously purged from the inside with instrument air making corrosion resistant internal section. Internal working parts are constructed from 300 series stainless steel, anodized aluminum or Buna-N.
- **Shock and Vibration Resistant** – the make and design of valve positioners is such that they have high natural frequency coupled with pneumatic damping. It is unaffected by vibration, acceleration up to 2 G's, and frequencies to 500 Hz.
- **For Single or Double-acting Actuators** – The valve positioner is versatile usable with either single or double acting actuators.
- **Standard Mounting** – Valve positioners use the standard mounting. By changing the cams and follower arms, the same positioner can be used on both linear and rotary actuators. This results in fewer required spare parts.

- **Easily Field Reversed** – A reversal of action in the field is achieved by simply turning the cam over, reversing the anti-backlash spring and changing the output tubing.
- **Insensitive to Mounting Position** – Positioners can be mounted in any orientation.
- **Simple Calibration** – Easy calibration as there is minimal interaction between zero and span. For protection and to discourage tampering, positioner adjustments are totally enclosed.
- **Split-Range Service** – Standard signal ranges are 4 - 20 mA for the electro-pneumatic (I/P) module and 3-15 psi (0-1 Bar) for the pneumatic (P/P) model. Optional ranges are 10-50 mA and 6-30 psi (0.4-2.1 Bar), respectively. All models can be calibrated for a 2 or 3-way split range.
- **Simplified Maintenance** – Ease in maintenance because of positioners simplicity, modular design and a few parts.
- **Regulator not needed** – Designed to withstand 150 psi (10.3 bar) at all parts, the valve positioners are insensitive to supply pressure fluctuations.
- **Low Air Consumption** – Steady state air consumption is .25 SCFM @ 60 psi (4.1 Bar) supply.
- **Changeable Flow Characteristics** – Easily changed cam provides characterized flow feedback.
- **High Air Flow Gain Model** – Standard on 200 square inch actuators and above, optional on others.
- **Output Gauge Helps Monitor Unit:** – Permits easy verification of transducer and positioner calibration as it indicates transducer output to the positioner.

HiFlo Positioner Specifications

Specification	Pneumatic Module
Input signal range:	3-15 psi (0-1 Bar), 2 or 3-way split range; 6-30 (0.4-2.1 Bar) psi, 2 or 3 and 4-way
Supply pressure	30 psi to 150 psi (2.1 to 10.3 Bar)
Ambient Standard model: temperature limits	-20° to +185° F (-30° to 85° C) Ext. temp, model: -50° to +250° F (-46° to 121° C)
Connections	Supply, instrument and output: 1/2-inch NPT; Gauges: 1/8-inch NPT
Standard materials	Stainless steel, anodized aluminum, nickel-plated steel, epoxy powder-painted steel and Buna-N
Net weight 3lbs.	(1.4kg)

HiFlo Positioner Performance*

HiFlo Positioner Performance	Pneumatic Module
Independent Linearity - Maximum deviation from a best fit straight line	±1.0% F.S.
Hysteresis - Maximum position error for the same value of input when approached from opposite ends of the scale.	0.5% F.S.
Repeatability - Maximum variation in position for the same value of input when approached from the same direction.	0.2% F.S.
Response Level - Maximum change in input required to cause a change in valve stem position in one direction.	0.2% F.S.
Dead Band - Maximum change in input required to cause a reversal in valve stem movement.	0.3% F.S.
Resolution - Smallest possible change in valve stem position.	.1%F.S.
Steady State Air Consumption @ 60 psi (4.1 Bar)	.25 SCFM
Supply Pressure Effect - Position change for a 10 psi (0.7 Bar) supply pressure change.	.05% F.S.
"Open-loop" Gain - Ratio of cylinder pressure unbalance to instrument pressure change with locked stem.	300:1 @60 psi
Maximum Flow Capacity @ 60 psi (4.1 Bar)	1.1 SCFM
Frequency Response - (With sinusoidal input of ±5% F.S. centered about 50% F.S.)	-6 dB Frequency -71°
Stroking Speed	- Closed to open - Open to closed
	2.3 in/sec. 1.3 in/sec.

* Data is based on tests of the HiFlo positioner mounted on a double-acting cylinder actuator having a piston area of 25 square inches with a valve stroke of 1.5 inches (38mm) and 60 psi (401 Bar) supply pressure instrument. single was 3-15 psi (0-1 Bar) with pneumatic module

HiFlo

Operation

Figure 4 shows a valve positioner . The valve positioner is a force-balanced instrument, with pneumatic module installed on a double-acting actuator for air to open action. Positioning is based on a balance of two forces; one proportional to the instrument signal and the other proportional to the stem position.

A downward force is activated as the signal pressure acts upon the diaphragms in the instrument signal capsule, through the follower arm and cam, the motion of the actuator stem is transmitted to the top end of the feedback spring resulting in the varying of tension in feedback spring as stem position changes.

The system will be in equilibrium and stem will be in the position called for by the instrument signal when these opposing forces balance exactly. The balance will move up or down and by means of the spool valve, will change the output pressures and flow rate if these opposing forces are not in balance. This will lead to the piston to moving until the tension on the feedback spring opposes exactly the instrument signal pressure.

The detailed sequence of positioner operations are as follows: An increase in the instrument signal forces

the instrument signal capsule and balance beam downward. This motion of the balance beam also pulls the pilot valve spool downward from its equilibrium position. This opens the pilot valve ports, supplying air to port 1 and exhausting air from port 2. This causes the actuator piston upward.

Proportionally to the valve position, to counter the force generated by the instrument signal capsule, the piston continues to stroke upwards until force in the feedback spring increases sufficiently. At this point the balance beam and spool begin to return to equilibrium position. As the valve spool ports start to close, the air flow rate to the actuator is decreased.

The feedback spring tension force will equal the force generated in the instrument signal capsule after the piston has reached the required position. The balance beam and instrument signal capsule will remain in their equilibrium positions with no air flowing to the actuator until a change in the instrument signal is made.

A proportional downward movement of the actuator piston and stem is affected by a decrease in the instrument signal which reverses the described actions.

Figure 4 : Positioner Schematic for Air-to-Open (Retract)

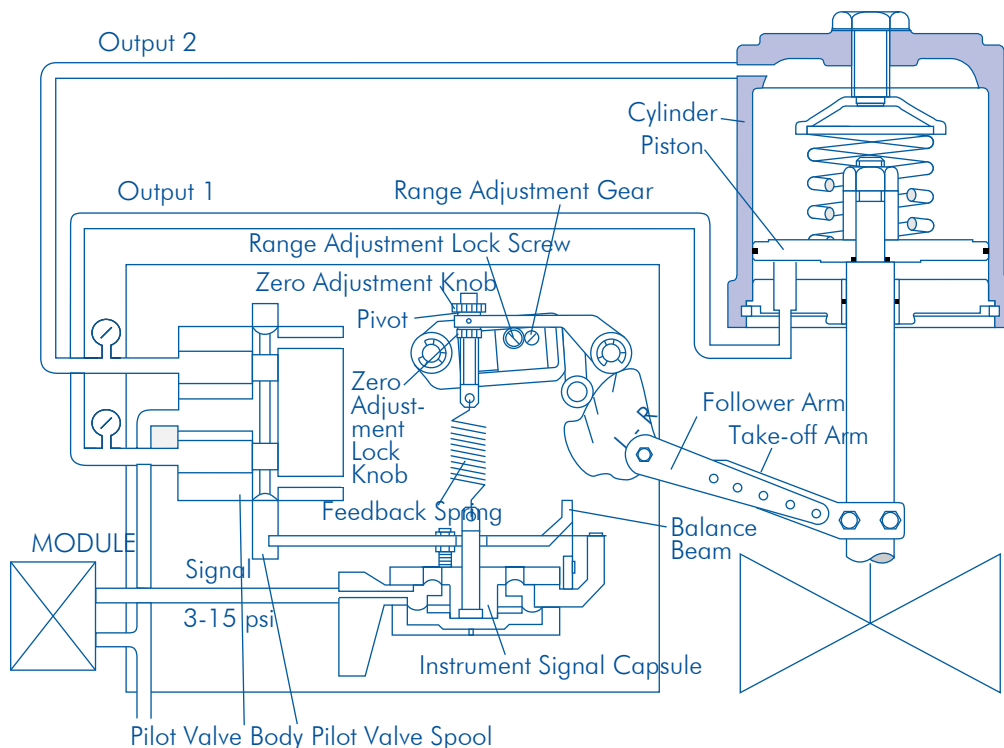

HiFlo

Mounting with different models/make

The uniqueness and principal feature of the HiFlo positioner is that it can be mounted on any pneumatic actuator, both single and double acting. Diagrams presented herewith show the mounting dimensions and standard follower arms that are available.



HiFlo mounts easily on a diaphragm actuator.



HiFlo Positioner comes standard on a Mascot GFlo

Optional Models

- Extended Temperature : Built with Fluorosilicone
 - diaphragms and O-rings
 - for temperatures -
 - 50°F to 250°F
- Oxygen Service : Built with Fluorosilicone diaphragms
 - and O-rings cleaned and
 - assembled in a clean room.
- Piped Vent : To vent off positioner exhaust used
 - for natural gas operations.



The HiFlo positioner is designed to mount on most rotary valves

HiFlo

Mounting dimensions

Linear Stroke Actuators

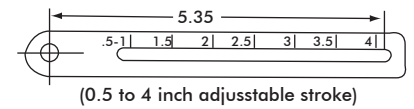
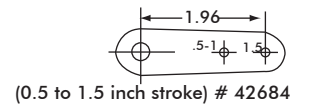
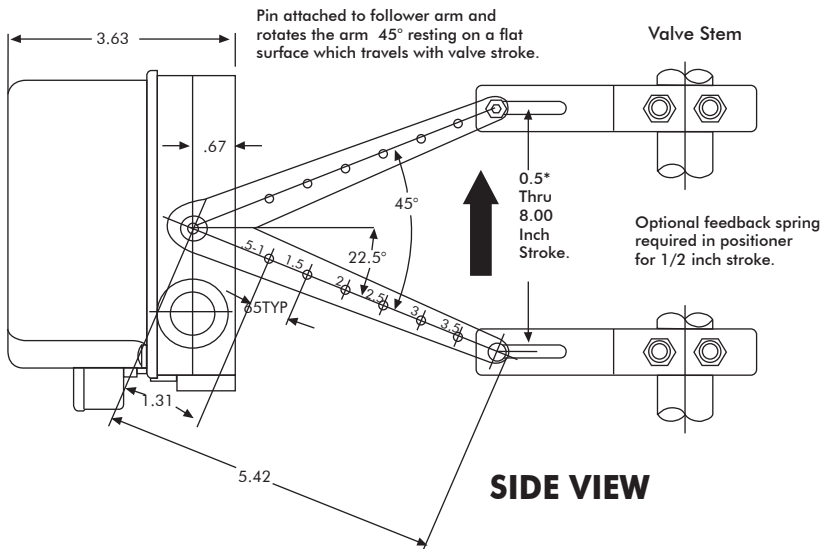
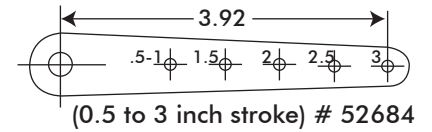
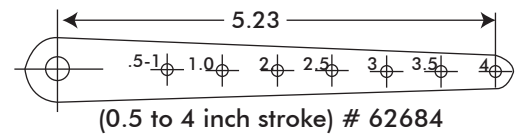
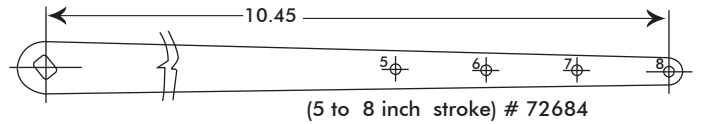
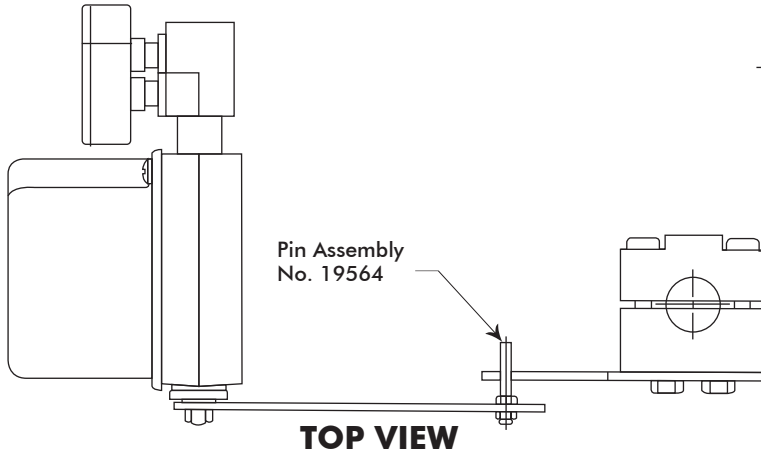

Standard Arms Available For linear Mounting

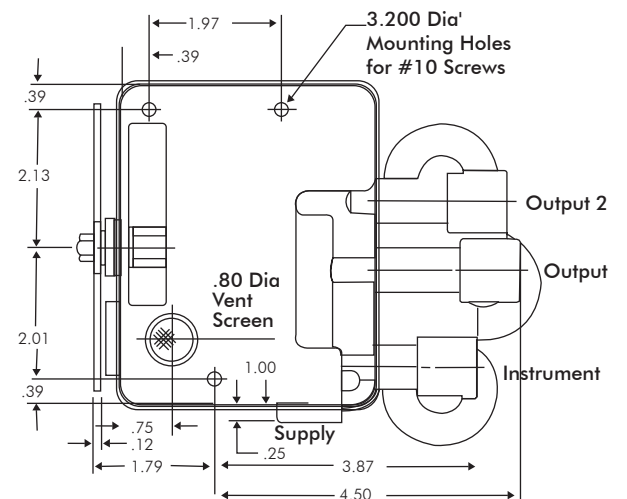
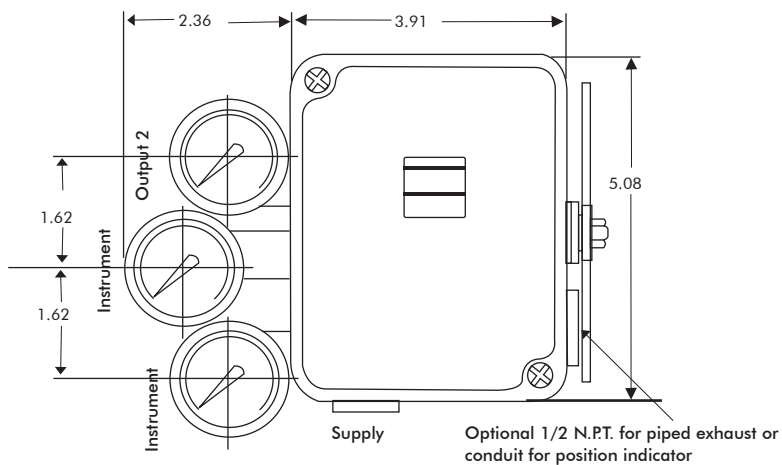

HiFlo

Mounting Dimensions



Our reputation

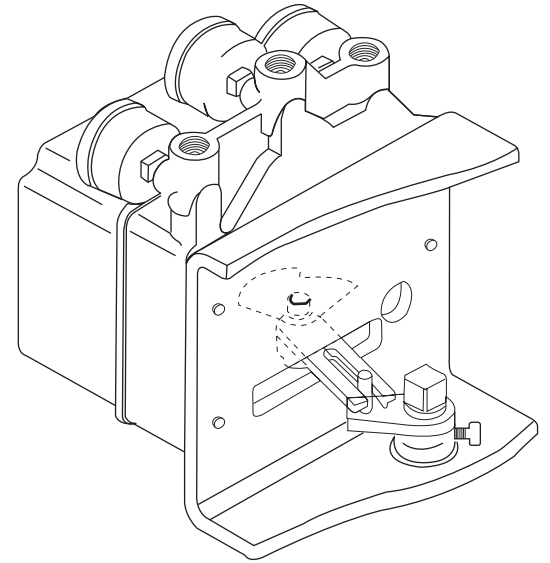
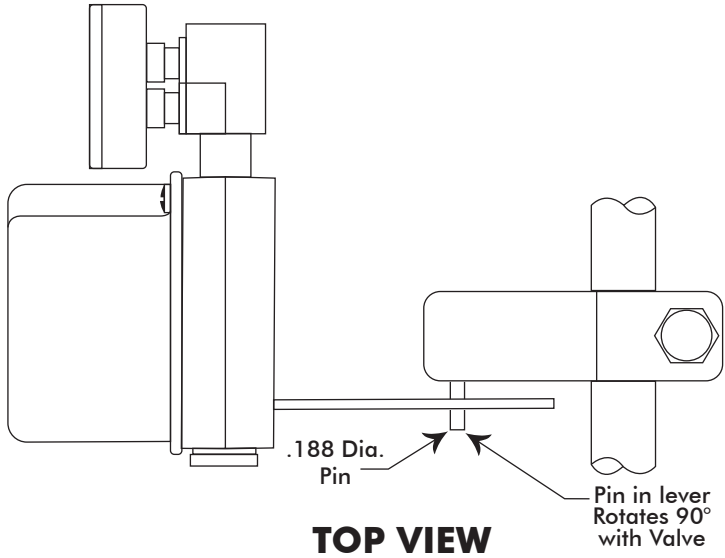

Typical Rotary Mounting

NOTE : Dimension X and Y (Radius of pin from valve stem Centerline) are a function of Z0- Z0 and solve for X and Y, using the following equations:

$Z = Z0 + .670X = .765 X Z$
 $Y = .414 X Z$ Each follower arm will work with particular range for X Values.

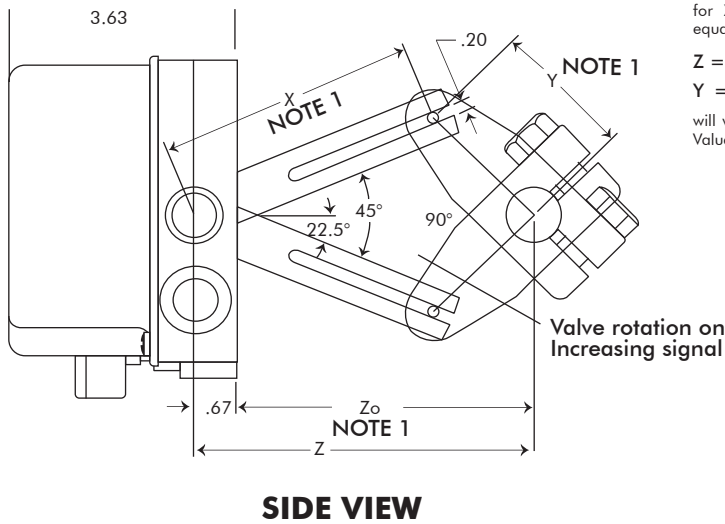
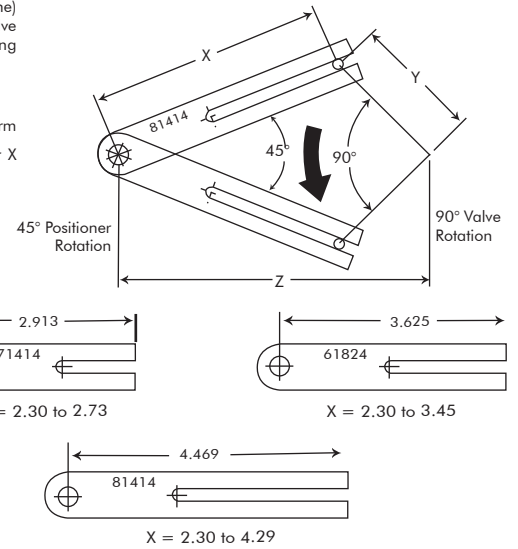

Standard Arms Available For Rotary Mounting

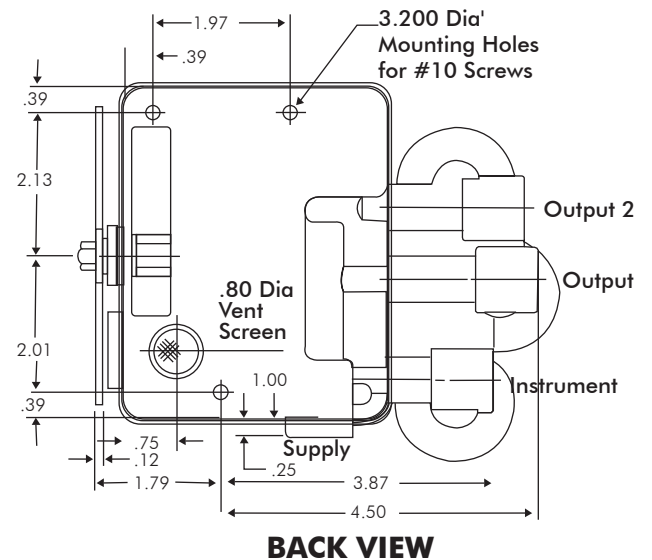
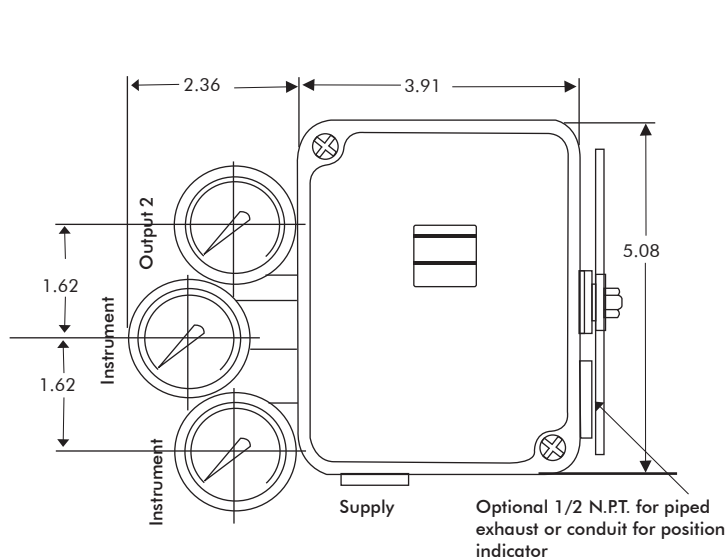

HiFlo

Ordering Information

Ordering Information

We need the following information when you order the HiFlo positioner. This helps you get accurate material and timely delivery thereby leading to great satisfaction of serving you in the best possible way. You are requested to specify the desired part numbers.

LINEAR ACTUATOR

When ordering a positioner for a pneumatic linear actuator, you should choose two part numbers; one from Section 1 which provides positioner part numbers for each model, and another from Section 2 which contains follower arm part numbers.

SECTION 1: Pneumatic Positioner

Model with 3-15 psi Span*

□	□	H Series	H Series	H Series	H Series
			Ext. □	Oxy. □	Piped
□	□	□	Temp. □	Ser. □	Vent
□	Std. □	Air-to-Open** □	89934 □	70764 □	31684 □ 51684
□	Stroke □	Air-to-Close □	99934 □	80764 □	41684 □ 64644
□	Short □	Air-to-Open □	61684 □	81684 □	02684 □ 22684
□	Stroke □	Air-to-Close □	71684 □	91684 □	12684 □ 32684

* Can be split ranged 2:1 or 3:1 without additional parts.

** The cam can be turned over in the field for opposite air action.

SECTION 2: Follower Arm Kits for

Pneumatic Linear Actuators

□	Stroke Range*** □	Part Number
□	1/2 - 1.5 □	42684
□	1/2 - 3 □	52684
□	1/2 - 4 □	62684
□	5-8 □	72684
□	1/2-4 □	Consult
□	Adjustable □	Factory

*** For a 1/2" stroke on a 25 or 50 square-inch actuator, or for a 3/4" stroke on a 100 or 200 square inch actuator, select the short stroke positioner model.

MODELS

HiFlo Extended Temperature
HiFlo Oxygen Service, HiFlo Piped Vent

90° TURN ROTARY ACTUATORS

When ordering a positioner for a pneumatic rotary actuator, you should select two part numbers; one from section 3 which provides part numbers for each positioner model, and another from section 4 which includes part numbers for the follower arm.

SECTION 3 - Pneumatic Positioner

Model with 3-15 psi span *

□	Installed □	HiFlo □	HiFlo □	HiFlo □	HiFlo □
□	Cam **** □	□	Ext. □	Oxy. □	Piped
□	25, 50 □	B □	46584 □	66584 □	82684 □ 03684
□	and 100 □	C □	56584 □	76584 □	92684 □ 86584
□	sq. in Act.				

* Can be split ranged 2:1 or 3:1 without additional parts. Also available are positioner models with 6.30 psi span and the same split ranges.

**** The cam can be turned over in the field to the opposite side "B" or "C". To select the correct positioner model choose either "B" or "C" from the DF Series cam Characteristics chart.

When installed on a DF Series valve, the signal Vs flow characteristics can be either equal percentage or linear based on air action as well as cam characteristics. See below

DF Series Cam Characteristics

□	□	Equal Percentage □	Linear
□	Air-to-Open □	B □	C
□	Air-to-Close □	C □	B

SECTION 4: - Follower Arms for

Pneumatics Rotary Actuators

□	Actuator Size □	Part Number
□	(Inches)	
□	25 □	71414
□	50 □	61824
□	100 □	81414